

TAP _____ D.P.
 _____ PLCS EQ SP
 ON A _____ B.C.
 STRADDLE CL

E DRILL THRU
 4 PLCS AS SHOWN

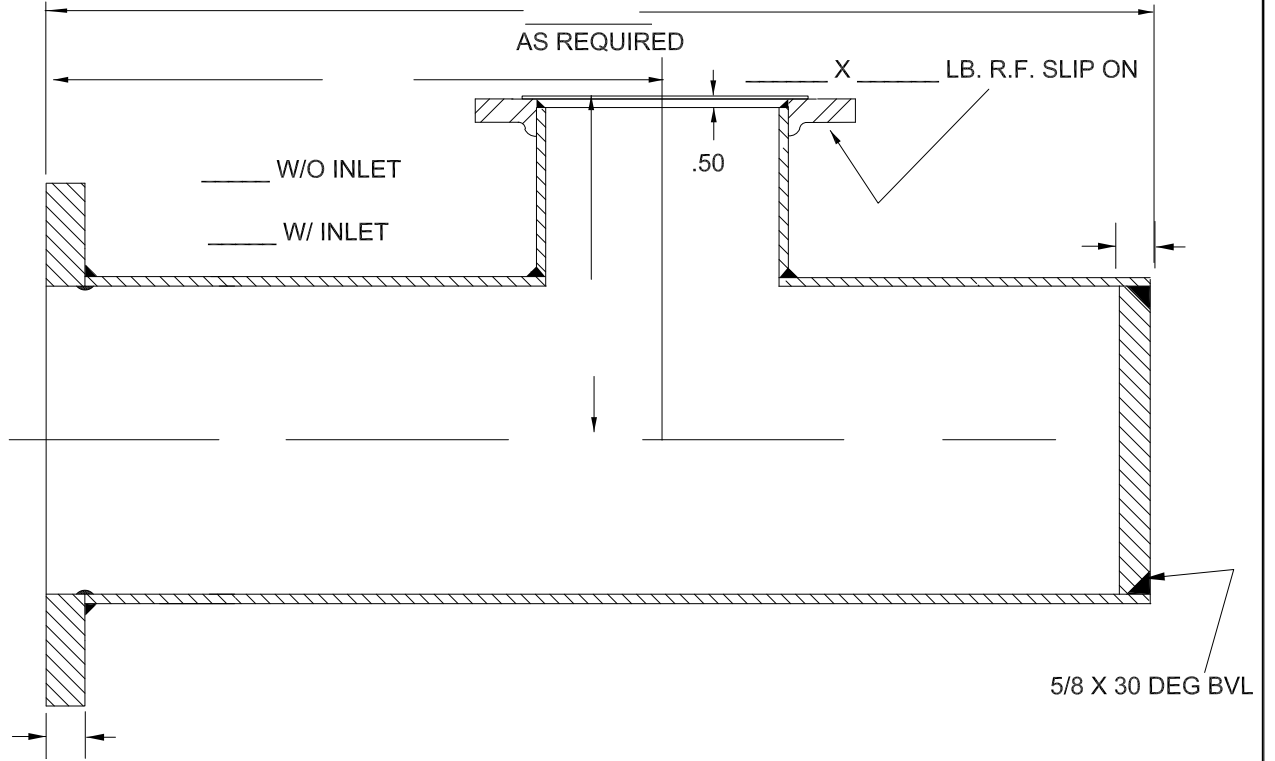
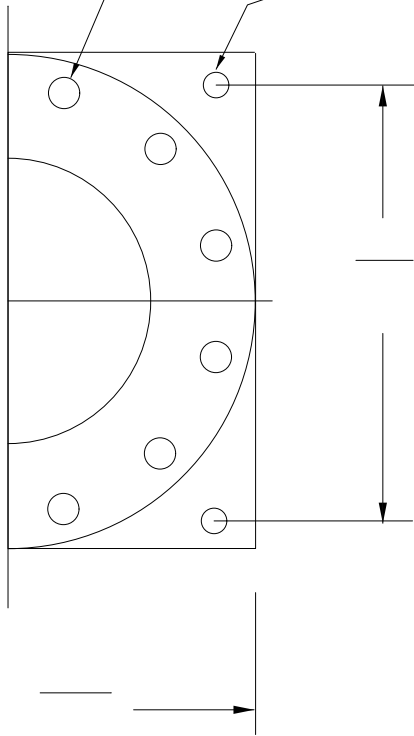

WELD NOTES:
 ALL FILLET WELDS OR BETTER

Tolerances Unless Otherwise Noted		VTS Vertical Turbine Specialists Lubbock, Texas		
1 Place Decimal (X.X)	± 0.1	MATERIAL	SCALE	DWG. BY
2 Place Decimal (X.XX)	± 0.02		N/A	SRD
3 Place Decimal (X.XXX)	± 0.005		APPR. BY	
Fractions	± 1/16	TITLE		
Angles	± 0-30'	BARREL		
All Dimension In Inches Break All Machined Corners		DATE	PAGE	DRAWING NO.
		08-OCT-2007	1 OF 1	